

Divar Wall-Divar Roof

Apparecchio montaggio a parete/soffitto
Surface/roof mounted luminaire

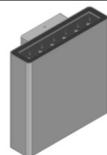

Divar wall double 24W

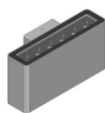

Divar wall mono 12W
Divar wall soft double 12W
Divar wall soft mono 6W

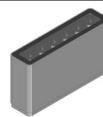

Divar roof 12W
Divar roof soft 6W

9010...X 9010...X 9010...X



IP65-3000K-4000K - 220-240Vac
Made in Italy

interasse foratura di montaggio:
Mounting distance:

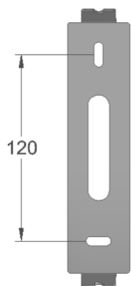

Divar Roof

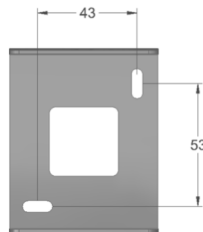

Divar wall mono
Divar wall soft double

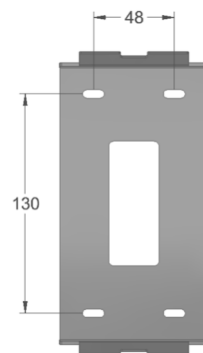

Divar Wall double

Montaggio su muro:
Wall mounting:

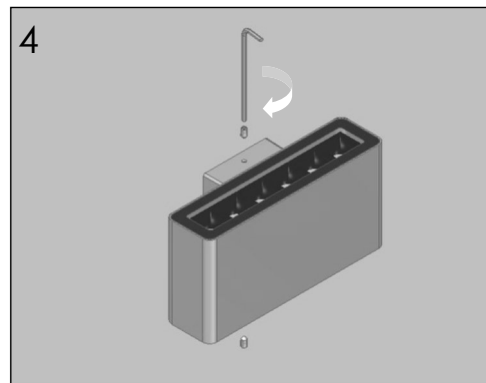
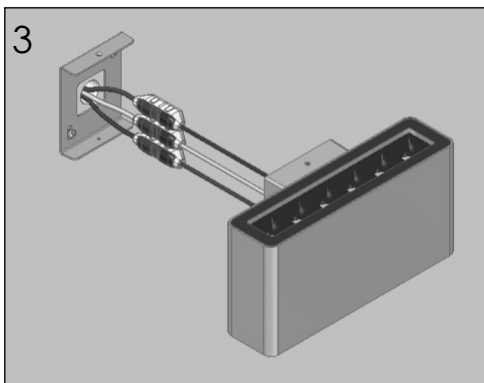
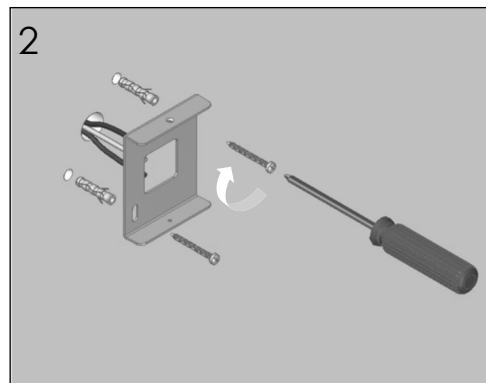
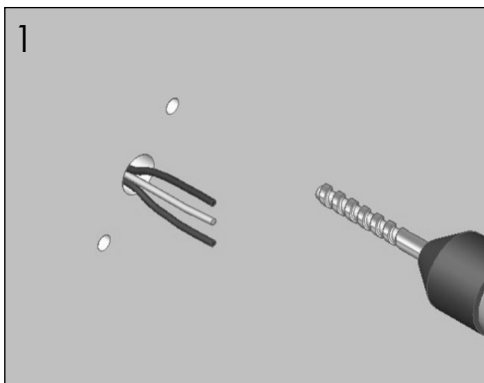

Montaggio su soffitto:
Solo modelli Roof

Ceiling mounting:
Roof models only:

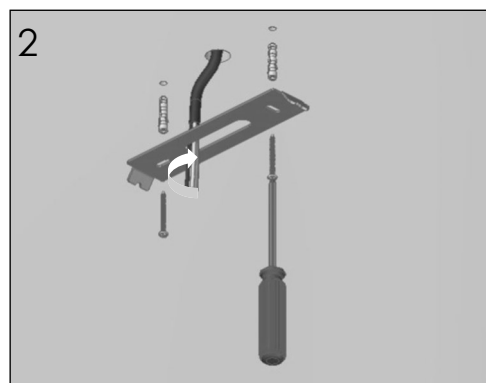

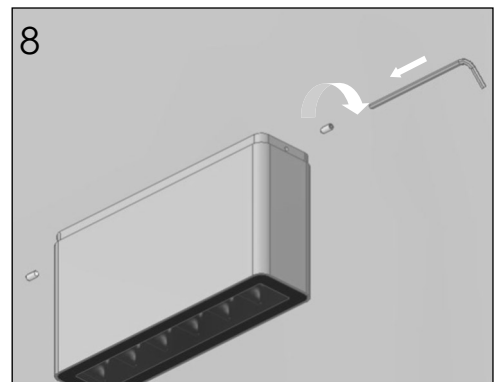
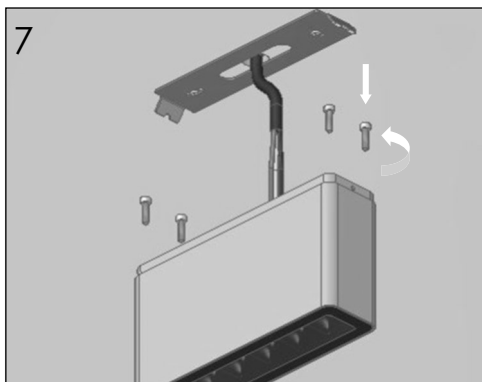
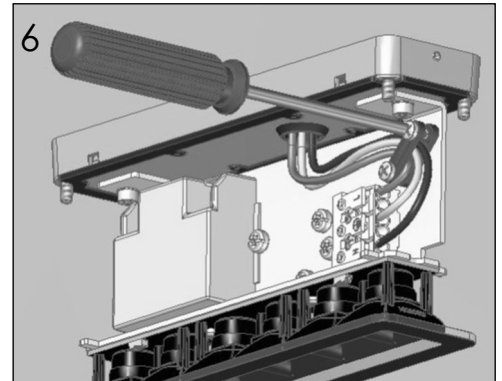
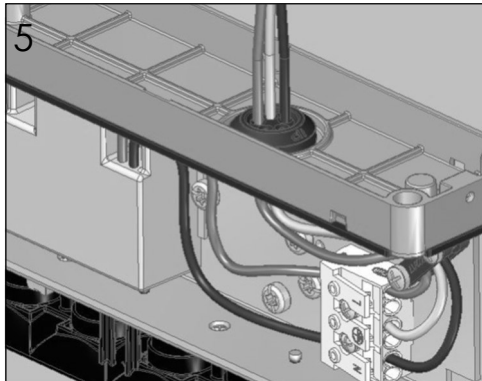
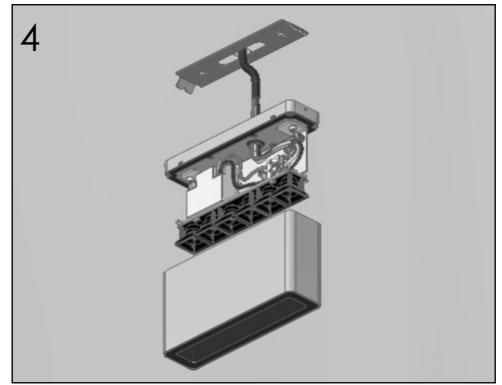
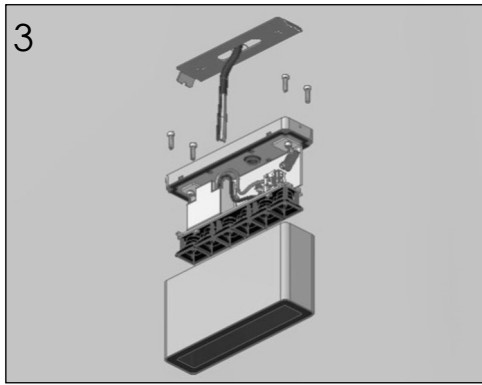

Il sistema di connessione permette l'utilizzo di cavi 0,75-1,5mm² per il lato rosso e 1,5-2,5mm² per il lato blu. Utilizzare il lato blu per connettere i cavi provenienti dalla rete elettrica.

The connection system allows the use of 0,75-1,5mm² wires for Red side, 1,5-2,5mm² for Blue side. Blue side for power supply cables.

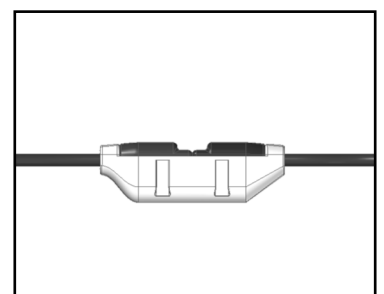
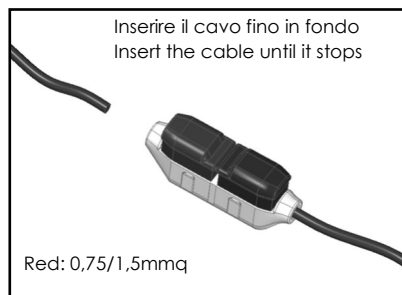
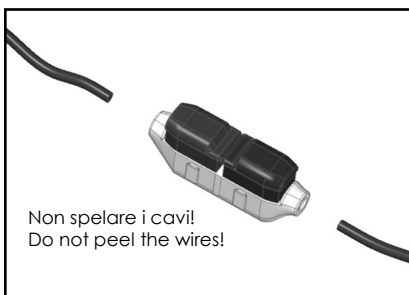



L'installazione dell'apparecchio deve essere effettuata da personale qualificato e in osservanza delle disposizioni nazionali di sicurezza.

The installation and maintenance of the fixture must be carried out by qualified staff and always be in compliance with local regulation in force.



Prima di effettuare qualsiasi intervento sull'apparecchio togliere l'alimentazione elettrica; il produttore non si assume alcuna responsabilità per danni causati dall'impiego o installazione non appropriate.

Be sure the fixture is disconnected from the power before executing maintenance. Manufacturer won't be responsible for damages arising from the use or wrong installation of the fixture.



La sicurezza dell'apparecchio è garantita solo con l'uso appropriato delle seguenti istruzioni, pertanto è necessario conservarle. Safety of the fixture is granted only by respecting the installation manual therefore it is important to keep it for future consulting.

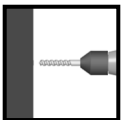

Per il fissaggio utilizzare tasselli ad espansione di tipo idoneo al materiale di supporto su cui viene applicato il prodotto (mattoni, calcestruzzo gesso legno ecc).

Use expansion bolts suitable for the material of the surface (brick, concrete, wood, gypsum etc...).



Non fissare direttamente la sorgente luminosa durante il suo funzionamento. Gruppo di rischio 1

Do not look directly at the light source. Risk Group 1

Direttiva 2002/96/CE rifiuti di apparecchiature elettriche ed elettroniche /RAEE:

Directive 2002/96/CE Waste Electrical & Electronic Equipment (WEEE)

A fine vita dell'apparecchio togliere l'alimentazione effettuare lo smontaggio e conferire tale prodotto negli idonei centri di raccolta differenziata dei rifiuti RAEE (Rifiuti Elettronici ed Elettrotecnici) oppure riconsegnandoli al rivenditore al momento dell'acquisto di nuova apparecchiatura. Tale operazione permette, grazie al riciclo differenziato, di dare nuova vita ai materiali componenti diminuendo l'impatto ambientale.

At the end of the fixture's life, disconnect it from the mains and disassemble it and send it to the appropriate waste collection center in compliance with WEEE (Electronic and Electro-technical Waste) or return it to the retailer when purchasing new equipment. This operation allows, thanks to differentiated recycling, to give new life to the components and to reduce the environmental impact



L'installazione all'esterno (prati, giardini, aiuole) comporta particolare attenzione all'interazione chimica con i prodotti fertilizzanti, diserbanti, calce e prodotti chimici in genere. Evitarne il contatto diretto con l'apparecchio.

Outdoor Installation (garden,) requires attention on the use of chemical agents and material containing them (lime, fertilizer weedkiller..): avoid the direct contact with the fixture.



Evitare per quanto possibile l'installazione all'esterno in condizioni climatiche avverse (pioggia forte umidità) per evitare accumulo di condensa all'interno in caso di apertura del prodotto.

Avoid the maintenance and installation in presence of high humidity or rain, in order to avoid accumulation of moist internally the fixture.



Il sistema di connessione per gli apparecchi IP deve avere un grado di protezione uguale o superiore al grado IP dell'apparecchio.

The connection must be done of the same of higher IP degree of the fixture.



In caso di rottura dello schermo o di qualsiasi altra parte (led compresi) l'apparecchio non può essere utilizzato. Contattare Diomedee per la sostituzione della parte danneggiata.

In case of breaking of any part (even the light source) the fixture should not operate and the replacement of any part should be made by authorized personell only, please contact DIOMEDE for more information.